

**MOTORI AUTOFRENANTI A DISCO CHIUSI A VENTILAZIONE ESTERNA
SELF-BRAKING ENCLOSED SELF-COOLED ELETTRIC MOTORS**

TIPO TYPE	A	B	C	D	L	L1	M	O	P	Q	R	G	S	U	Y	W	FRENO BRAKE (L)	FRENO BRAKE (L1)
MCFA 80	160	130	110	19	360	353	40	137	3	12	160	-	75	9	5	21.5	80S	70S
MCFA 80	200	130	165	24	335	328	50	137	3	12	160	-	75	11	6	27	80 S	70 S
MCFA 90	160	110	130	19	440	430	40	148	3	12	178	-	75	9	8	21.5	100S	80S
MCFA 90	200	130	165	24	405	395	50	148	3	12	178	-	75	11	8	27	100S	80S
MCFA 100R	200	130	165	24	427	417	50	157	3	12	195	-	75	11	8	27	100S	80S
MCFA 100R	250	180	215	28	406	396	60	157	3	12	195	-	75	8	8	31	100 S	80S
MCFA 100	200	130	165	24	459	453	50	165	3	12	207	-	75	11	8	27	110S	100S
MCFA 100	250	180	215	28	429	435	60	165	3	12	207	-	75	15	8	31	100S	110S

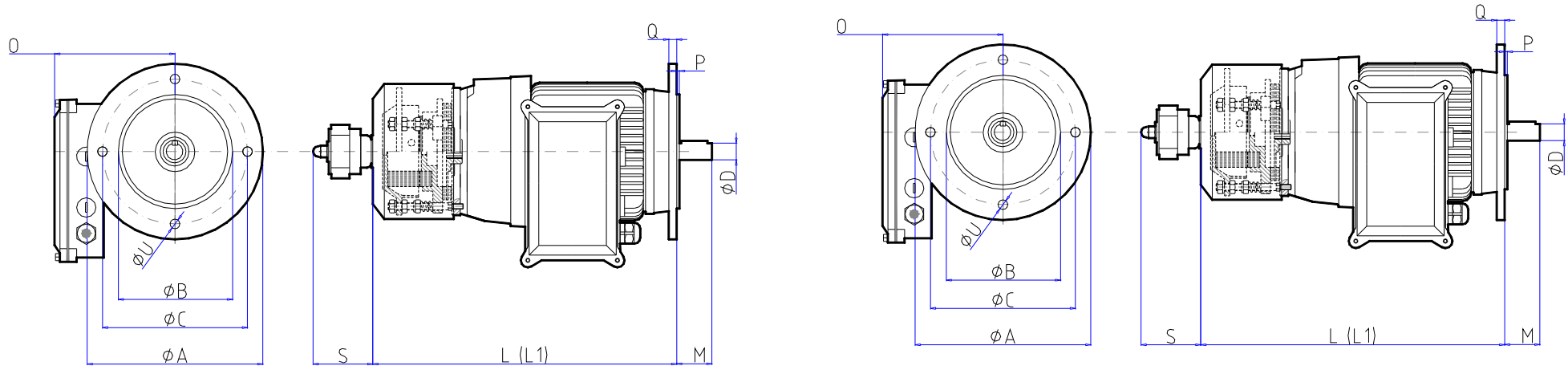

TIPO TYPE	A	B	C	D	L	L1	M	O	P	Q	R	G	S	U	Y	W	FRENO BRAKE (L)	FRENO BRAKE (L1)
MCFA 112	200	130	165	24	478	484	50	169	3	12	230	-	75	11	8	27	110 S	100S
MCFA 112	250	180	215	28	475	465	60	165	3	12	230	-	75	15	8	31	120S	110S
MCFA 132L	250	180	215	28	589	-	60	188	3	12	252	-	-	15	10	31	120MSDD	-
MCFA 132C	300	230	265	38	546	-	70	188	3	12	252	-	-	15	10	41	120MSDD	-
MCFA 132XXL	250	180	215	28	634	603	60	188	3	12	252	-	-	15	8	31	140MSDD	K8
MCFA132XXL	300	230	265	38	591	560	70	188	3	12	252	-	-	15	10	41	140MSDD	K8

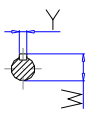